



# KlevaKlip Adjustable Joist Kit AJ45KIT

(For building decks over concrete)

**Play Installation DVD at [www.klevaklip.com.au/Joist-Supports-install-info](http://www.klevaklip.com.au/Joist-Supports-install-info)**

## Installation Steps for AJ45KIT Adjustable Joist Kit

**Note:** Each Adjustable Joist Kit contains 16 x Joist Supports + Base Plates, 32 x M10 100mm Galvanised Bolts, 64 x M10 Nuts, 32 X M10 washers and 16 x 60mm Galvanised 12mm Dynabolts.

### Step 1- Positioning Joist Support Base Plates

Mark out positions for the base plates on the concrete slab (see table for minimum span requirements for 70mm, 90mm and 140mm joists) These are all based upon "continuous span" with joists at 450mm between centers. Either use a "straight edge" or run a string line from one of the notches in the outer base plates and flick the line for the positions of the internal base plates.

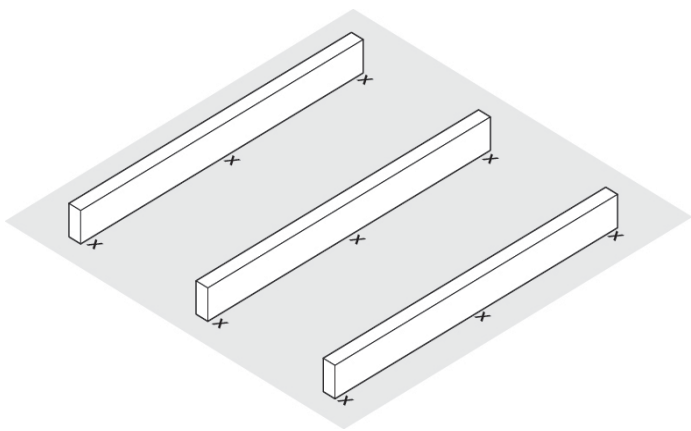

### Step 2 - Drill Holes for Base Plates

Drill holes for base plates (or for joist supports if securing them directly to concrete) using 12mm masonry bit.

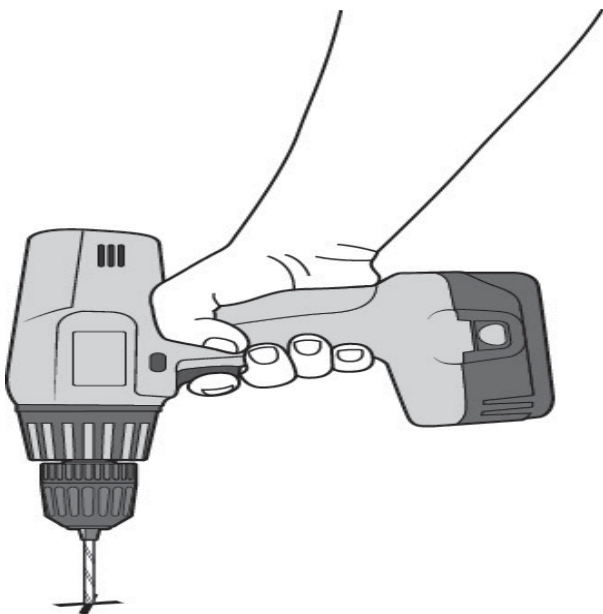

### Step 3 - Inserting M10 Hex Head bolt

Insert 2 x M10 100mm hex-bolt through base plate. Note: The KlevaKlip Adjustable Joist Kit system is designed to provide a "top of the joist" height from 86mm to 200mm depending on what height joists you are using.

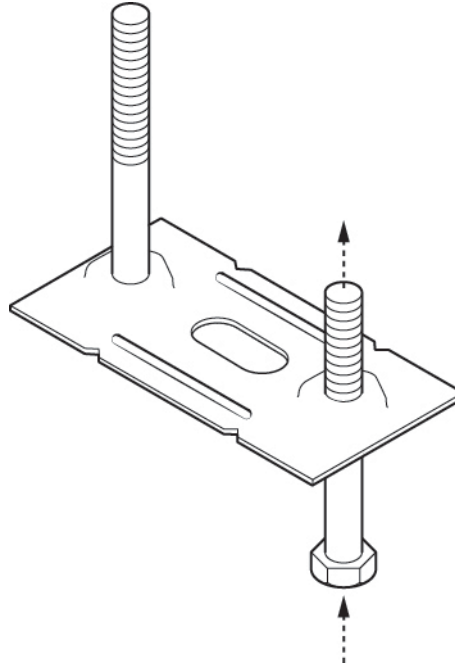

### Step 4 - Fixing Base Plate

Fix base plate to concrete using 12mm dynabolts. Repeat steps 1 - 4 for all base-plates to be installed.  
**Tip No. 1** before fully tightening Dynabolts, either use a straight edge or run a string line along the edge of the base-plate vertical bolts to ensure they line up correctly. Adjust base-plate in the slot if required.

**Tip No. 2** Check all base-plates are "square" to the above-mentioned straight edge or stringline

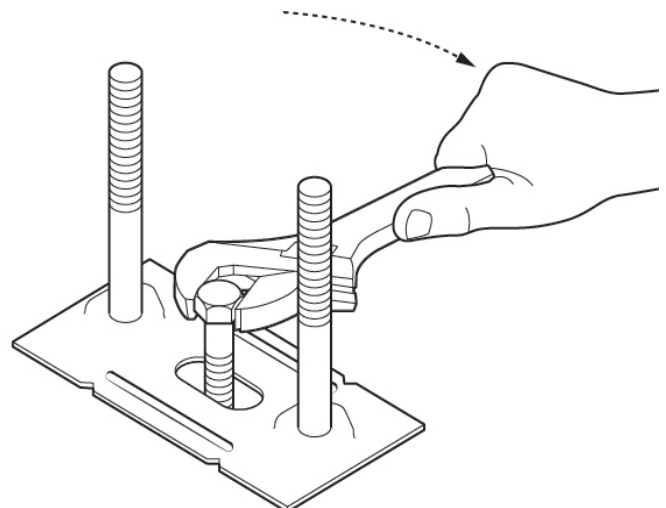

## Step 5 - Attach Joist Support

Attach joist support onto hex bolts and adjust to approx height required. Semi-tighten nuts – this will tighten the whole structure enough to withstand joists being inserted and secured.

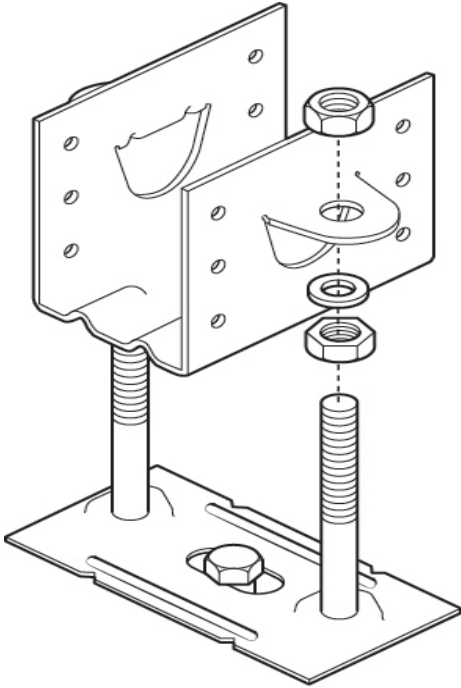

## Step 6 - Insert Joist into Joist Support

Insert joist into joist support and secure with minimum 2 of 3.2mm x 30mm connector nails or 8g x 30mm stitching screws on each side of the joist support.

**Tip:** – when fixing nails, brace the other side of the joist Support with your foot to minimise vibration

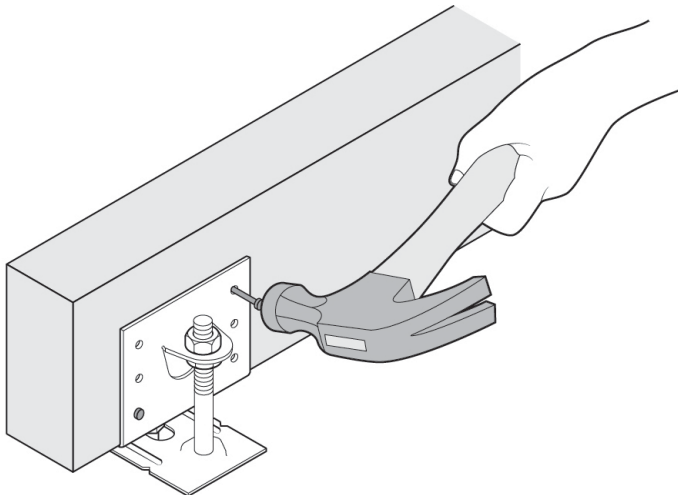

## Step 7 - Joist Adjustment

Adjust joist to correct height using dumpy or laser-level or string line. (Note – you will need to loosen the nuts off if the joist support height needs adjusting)

**Fully tighten nuts locking the Joist Supports.**

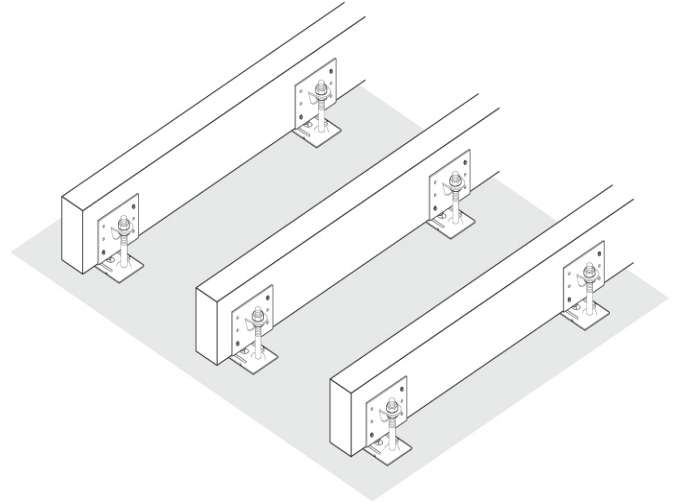

### Load Bearing:

The KlevaKlip Adjustable Joist Kit has been independently tested to support a load bearing capacity of 350 kg per square metre when used at the recommended joist spans listed below.

### Corrosion Protection:

KlevaKlip Joist Supports and Base Plates have been hot dip galvanised in accordance with Australian Standards AS/NZS 4680:2006 (ISO 1461)

### Span requirements for base-plate positioning

All based upon "continuous span" with joists at 450mm between centres.

	Recommended Span (mm)	Maximum Span (mm)
70 x 45mm MGP10	800	1200
90 x 45mm MGP10	1000	1500
90 x 45mm MGP12	1200	1600
*120 x 45mm MGP10	1200	1800
*140 x 45mm MGP10	1200	1800

\* Joist span limited by lateral loading on bolts

### 100mm M10 Bolts Minimum and Maximum Heights

Hex Head Bolt Length	Min Height to Bottom of Joist	Max Height to Bottom of Joist	Min Height to Top of 70/90mm Joist	Max Height to Top of 70/90/140mm Joist
100mm	16mm	60mm	86* / 106mm	130 / 150 / 200mm
** No Bolt	6mm		76 / 96mm	

\* If using bolts at low heights, to prevent the bolts protruding past the top of joist, the end of the bolt will need to be cut off. It is good practice to paint the cut end with metal primer.

\*\* When Using Joist Support Only.